

Exclusive! A new level in image quality reference home cinema technology in a small package

home cinema projector series

Action! M20

BrilliantColor™

>4000 : 1 contrast ratio

7x colour wheel

RealColor management



Exclusive BrilliantColor™ technology!

projectiondesign are proud to introduce an exclusive product – the Action! M20, featuring, as the only 720p projector, BrilliantColor™ technology! An innovation from Texas Instruments®, BrilliantColor™ is revolutionary in the way colours are processed and displayed. Dramatically increasing colour saturation and gamut, it gives home cinema a whole new dimension! projectiondesign have worked closely with Texas Instruments® to be the only company to offer this technology with true HD2+ DC3™ DLP™ displays!

Action! M20 home cinema projector

The projectiondesign Action! M20 builds on our award winning, high value, Action! model two HDTV projector. Using technology from our higher end projectors, it comes in at an extremely attractive price point, yet with an amazing image quality. High contrast, unsurpassed colour reproduction, and a near seamless image, it gives projectors at many times its price a run for the money.

Small, unobtrusive and beautiful

The Action! M20 has been designed specifically to be small and unobtrusive, yet retain reference level performance. Unbelievably small, it is practically unnoticeable when installed on the ceiling. To fit a range of interiors, the Action! M20 comes standard in three different automotive quality finishes; vanquish grey, maranello blue, and pearl white.

RealColor colour management suite

The Action! M20 takes full advantage of our exclusive RealColor colour management suite. Through uniquely characterising and calibrating each single projector as they leave the production line, we ensure every single one can reproduce a true D65 white point when switched on. RealColor has been developed to perfectly track gray scale throughout the dynamic range, and to result in perfect video colour reproduction.

Precision RGBCMY BrilliantColor™ technology colour wheel

The Action! M20 uses a very high precision colour wheel with six segments, Red, Green, Blue, Cyan, Magenta, and Yellow. Adding natural colours to the colour wheel results in far superior colour reproduction, greater dynamics and better shadow detail than other technologies, with special emphasis on colours found in natural images. In addition, the higher rotation speed of the colour wheel, combined with greatly increased data rates in image processing, reduce visible artefacts from other technologies to a minimum. The end result is an incredibly rich picture, with strong, clear colours.

v



Texas Instruments® single chip DLP™ technology ensures natural, saturated colors, perfect color uniformity, and a near seamless, film-like image. The high device and system contrast of more than 4000:1 negates the need for contrast enhancement through dynamic brightness variation, known to produce white crush and severe loss of detail when activated.



BrilliantColor™ adds a new dimension to the projected image by adding three extra colours to the colour wheel. Spinning at an unprecedented 7x, the extra colours add tonality and colours that are found in nature – for a natural smoothness in the picture. Gradations, flesh tones and low level detail scenes all benefit tremendously, providing a home cinema experience never before seen with single chip DLP™.



The included, backlit IR remote control features direct keys to most commonly used functions, such as one-key source access, brightness and contrast settings, as well as on-the-fly gamma curve changes. In addition, it gives easy access to the on screen menu, with intuitive settings and adjustment options. The Action! M20 features control over dedicated TCP/IP, through RS232 or via wire from the remote.



Sealed, optical architecture with lens shift gives flexibility in installation, and yields optimal performance. Preventing dust and contamination from entering the optical assembly for optimum purity. The aspherical lens elements and proprietary LD (Low Dispersion) glass gives a lens with excellent ability to resolve the finer detail. It is detail that creates stunning images, not only overall black/white contrast.

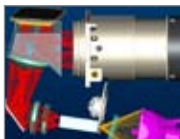

Unmatched attention to detail sets the Action! M20 in a league by itself. A massive molded magnesium chassis acts as a heat sink, reduces operating noise, and makes it virtually bomb proof. The sturdy chassis creates an incredibly stable platform for optics, mechanics and electronics. Lamp change is easy - out of the front panel of the projector without need to dismount it in the installation.



technical specifications

Action! M20

projector	display	concept	home cinema DLP™ projector
			single chip HD2+ DC3™ DMD™ exclusive BrilliantColor™ technology
			1280 x 720 resolution
			6-segment, 7x colour wheel, RGBCMY
		compatibility	1080i/p, 720p, 576i/p, 480i/p, PAL SECAM, NTSC
			digital and analogue RGB
optics and lamp		standard projection lens	1.95 - 2.43 : 1 (distance : screen width) zoom lens
			0.9 : 1 and 1.1 : 1 wide angle lenses available
		lens shift	20 - 125% vertical (with standard zoom lens)
		contrast	>4000 : 1 (typical)
		brightness	500 - 1000 ANSI lumen, continuously adjustable
		lamp	220W UHP™, adjustable power, 170 - 220W
		lamp life expectancy	3000 hours typical in standard power mode
			2250 hours in high power mode
connectivity		video	DVI-D (HDCP) (DVI and HDMI digital RGB)
			1x RCA (YPbPr, YCbCr) (component video)
			1x S-Video (s-video)
			1x RCA (composite video)
			HDD-15 (RGBHV, RGBS, RGSB, YUV)
		control	LAN (TCP/IP), RS232, USB
			IR remote control with IR repeater input
general		operating noise level	24 dB(A) typical in standard mode
		dimensions (d x w x h)	234 x 278 x 94 mm
		weight	2.9 kg
		available colours	pearl white, vanquish grey, maranello blue
		warranties	3 years limited warranty, 90 days/500 hours on lamp. Conditions apply

Screen sizes and throw distances

visible area w x h	screen size (diag.)	distance to screen		compensation
		cm	inches	
160 x 90	72	312	384	31
182 x 103	82	355	442	36
203 x 114	92	396	493	40
221 x 125	100	431	537	43
234 x 132	106	456	569	46
244 x 137	110	476	593	48

± 5% tolerances

Available colours



Optical lens shift

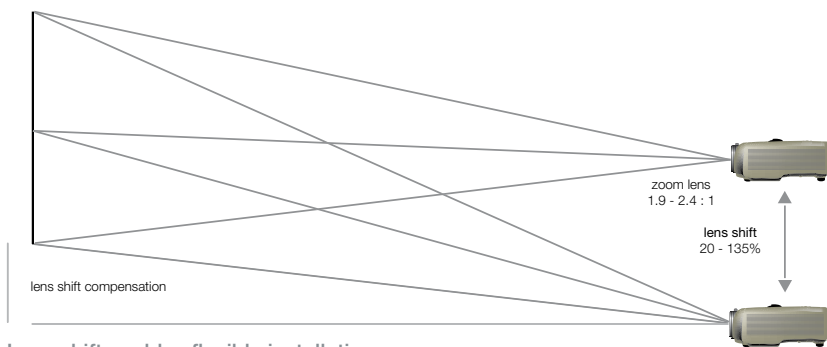

Lens shift enables flexible installations

The Action! M20 features 20 - 125% vertical lens shift. That means more flexibility with installations and no keystone correction needed for a perfectly rectangular image.

Standardised bolt-on ceiling mount interface

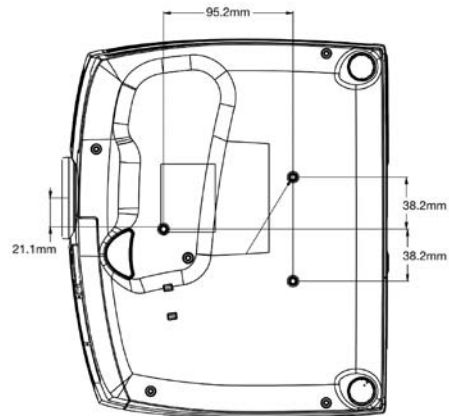

Distributed by:

