



PROJEKTIONSWAND SYSTEM INLINE SK 16x16cm



show control technology

Abmessungen der Projektionswand

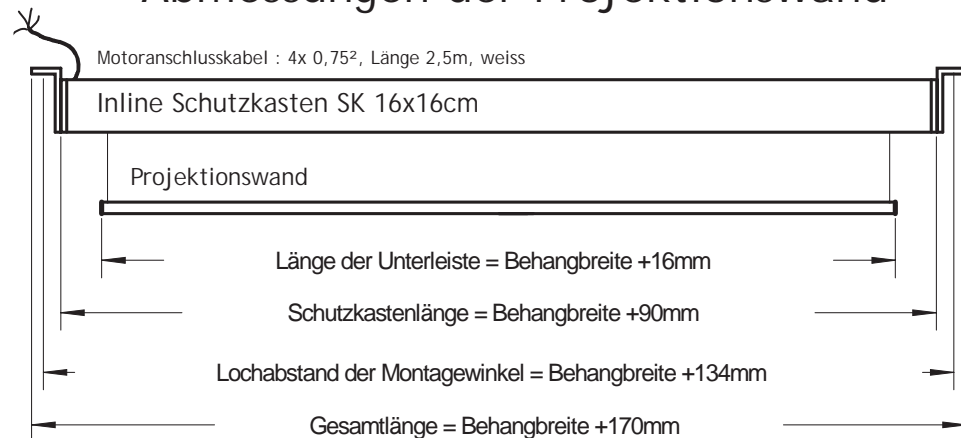

Gesamtlänge: +/- 3mm

Querschnitt Inline-Schutzkasten

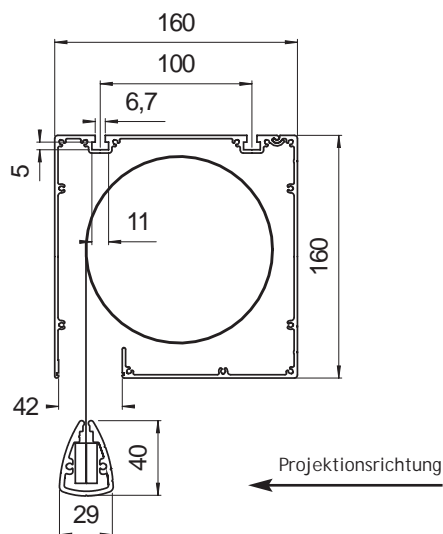

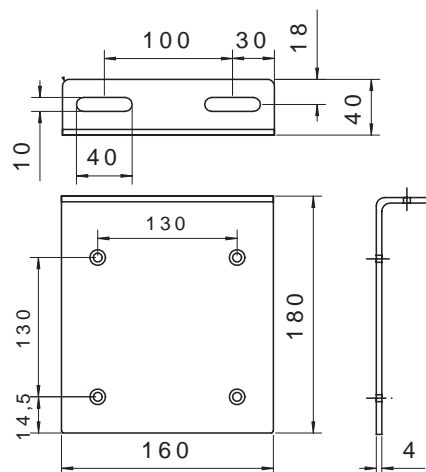

Universal Montagewinkel



Projektionswand mit Motorantrieb

Art. Nr.	Beschreibung		Abmessungen Schutzkasten	Kg netto	Kg brutto
BIM-SV400	Inline-Motor Strato, 4:3	400x300cm	SK 16x16cm	72	92
BIM-SQ400	Inline-Motor Strato, 1:1	400x400cm	SK 16x16cm	77	97
BIM-SD500	Inline-Motor Strato, 3:2	500x330cm	SK 16x16cm	93	118
BIM-SF500	Inline-Motor Strato, FS	500x400cm	SK 16x16cm	97	122

Projektionswand mit Motorantrieb und schwarzem Video-Rand

Art. Nr.	Beschreibung			Schutzkasten Abmessungen	Kg netto	Kg brutto
BIM-SV410/R5	Inline-Motor Strato, 4:3	410x310cm	400x300cm	SK 16x16cm	75	96
BIM-SV450/R5	Inline-Motor Strato, 4:3	450x340cm	440x330cm	SK 16x16cm	84	174
BIM-SV490/R5	Inline-Motor Strato, 4:3	490x370cm	480x360cm	SK 16x16cm	93	191
BIM-SC410/R5	Inline-Motor Strato, 16:9	410x310cm	400x225cm	SK 16x16cm	75	96
BIM-SC450/R5	Inline-Motor Strato, 16:9	450x340cm	440x248cm	SK 16x16cm	84	174
BIM-SC490/R5	Inline-Motor Strato, 16:9	490x370cm	480x270cm	SK 16x16cm	93	191

Andere Größen / Ausführungen / Farben / Zubehör auf Anfrage